

# Town of Bayview Roads and Parks Survey

The Town Board is developing a Road Management Plan and considering additional Park projects. Please take a moment to provide us with some feedback for planning purposes.

## Roads

The Town Road Committee recently provided the Board with a report on their findings and recommendations to the Board on our road system. Findings included the general condition of the roads was adequate, the current budget and other funding sources are not sufficient to do more than just maintain existing roads, and recommendations regarding equipment and maintenance programs. The Board has taken actions on the recommendations including upgrading the blades on our grader and beginning a rebuild of the surface of Maki Rd. from Washington Ave. to Hwy. 13.

1) What road do you live on? \_\_\_\_\_

Frostman 1	McCulloch 1	Big Rock Road 3
Friendly Valley 7	Maki Road 5	Komborski 3
Singer 4	STH 13 -18	Bodin 2
Howell 1	Bayview Park 1	Westgate 2
Burlager 3	Dryer 2	CTH C 1
Carrier 2	Washington 5	Johnson-Leino 2
Oak 1	Freedom Valley 4	Houghton Falls 3
Niemisto 5	Whiting Road 8	

2) What is your overall evaluation of the Town road system and maintenance?

24 good 40 adequate 12 inadequate 13 poor 6 no opinion

The red clay dirt with ¾" -1" stones is not road gravel material.

3) Would you support increasing the Town levy (approved by voters at a Town meeting) for road improvements? 32 yes 40 no 8 no opinion

The guys do a good job with what they have.

You get enough gas funds to do the roads.

I would support increasing the tax levy to increase the percentage of hard surface, paved roads.

4) What are your biggest road priorities or suggestions for the Town of Bayview?

If gravel roads cannot be paved, be sure that drainage is maintained so condition doesn't deteriorate. Use cold-patch on paved roads.

They all need work.

Repair washboards roads – fix catch all edges.

Roads are not maintained enough! Or maintained correctly! Roads need to be graded not drug!! There is plenty of gravel to cut in most places.

Long term blacktop program.

When grading the roads – go slow- you don't need to go so fast – you hit the ground here and there making a very rough washboard road.

Washboards everywhere – who grades anymore? Timely snow removal.

Roads with chuck holes – shoulders that do not drain water off road edges.

Be careful on the type of improvements we make. I don't see funding increasing from the state.

Gravel roads should be crowned, the drag does not allow for crown.

Better gravel – grading (Washington Ave)

Pot hole repair.

## Dust Control.

Prioritize grading and plowing in a timely manner. Mowing the entire right a way to eliminate the canopy over the road. Tree trimming and widening the mowed area is in many cases a waste of time and tax payer dollars. I would like to see meeting minutes posted on the town web site in a timely manner and posting meeting announcements on the website.

Separate issues: Maintenance –Good . Paved system – poor.

The roads used to be graded in a way that eliminated washboarding, etc. In the past three years or so conditions of the majority of our gravel roads have deteriorated. Less mowing and tree trimming – more timely grading and snow plowing.

Maintain until economy rallies.

Increase grading to control “washboarding”

Doing great –thank you.

Town crew working on roads instead of parks and recreation.

Keeping the roads dragged and or graded and the grass cut in the ditches.

Maintain as is. Blacktop is not a high priority and breaks down quickly in our climate.

Maintain present roads in present condition, unless improvements ultimately save money.

Maintain current roads as they are. 2- people

Keeping the few blacktopped roads maintained. Keeping main roads (highly used) well maintained.

Road maintenance schedule based on type of volume of use. Maintenance=frequency of grading, type of “gravel” necessary to maintain a quality surface.

Gravel road grading and snow removal.

Do not pave roads, rather maintenance of gravel.

Continuous grading – keep washboarding to a minimum.

The main artery roads – then secondary – more time or hire people to get work done.

Every 3 weeks roads should be graded by grader not the drag. All of the roads – including barren’s should be blacktopped.

Fill pot holes.

Set money aside annually for larger projects.

Currently – grading weekly- too much dust- way to rutty- need to smooth – black top roads.

From my limited experience, it seems like you are doing a good job prioritizing road work.

Main routes- there is and was a plan in place a few years back.

Please save money by discontinuing mowing operations and tree branch cutting along our beautiful country roads.

This is not “green”. Depletes our oxygen supply and burn fuel with toxic output.

1) Snow plowing (currently excellent) 2) Keep dust down. 3) grade the potholes and ripples. 4) Replace culverts and fix washouts.

Look for grants to try and blacktop Maki Road, the remainder of Burlager Road and Friendly Valley Road. Maki-Friendly Valley- Washington/Burlager.

Gravel perhaps, do something to improve Bayview Park Road, please.

Big Rock Repair. Crowns back on all roads, water should not stand on roads, ditches that flow. Log hours worked on each road, keep on file.

Stabilization of Big Rock south approach. Wait until after bird nesting & wild flower bloom before mowing deep into ditches.

Big Rock has many transverse cracks that are never filled.

Fix Big Rock Hill

Finish what you started Big Rock Road

Johnson Leino Road –East.

Maki Road needs attention

Paving Maki Road. 6 -people

Maki Road -3 people

Maki Road was *prepared* for asphalt in 1974 (Washington Ave to Big Rock Road) as part of Washburn Bypass, never materialized.

Maki Road to be blacktop as it is a very busy section 99% of traffic on Houghton seems to be resident traffic whereas, Maki is used by all, Road sign recommended for 35 mph as well, children play signs as a lot of children live on this road.2

Long range plan (Improvements to Maki Road with goal to blacktop)

Maki Road is a bit nasty – for some reason it always has been.

There are times Maki Road is almost impassable with 4 wheel drive. We have lost the running boards on the car as the vibration were so bad.

Improve Maki Road from Big Rock to STH 13.

Our biggest road priority is Maki Road. This road is considered a “cross town” road. Maki road is traveled by all types and sizes of vehicles from heavy duty construction trucks down to ATV’s and even horses! The town works hard on keeping it in the best possible condition, which is very time consuming, because this road needs so much attention we believe it is a good candidate for blacktop. Maki road gets very dangerous because of its “ripple” effect and the base of Maki Road and Washington Ave we have seen vehicles on the wrong side of the road traveling west up the hill with the danger of an oncoming vehicle, not to mention the dust which causes poor visibility. We believe Maki road needs to be blacktopped for the safety issues and the expense of gravel yearly, which over the years has proven to be in vain. Please consider our concerns and suggestions for the safety and the expense this road has caused for the township, not to mention the man hours. Thank you.

Maki Road should be the first road to receive improvements – poor condition!

Maki to Town Hall

Whiting Road needs ditch maintenance to reduce water travel and erosion on the road surface.

Just plow as soon as possible. (Whiting)

Whiting Road needs ditches on North side.

Pot holes on Friendly Valley

Dust abatement Friendly Valley

Improve Friendly Valley to Big Rock.

Pave Friendly Valley to Niemisto or Big Rock

1)Houghton Falls Road, complete 2) finish Friendly Valley Road 3) Maki Road

Blacktop gravel roadway between Washington Ave and Burlager Road. Also ditch on curve (east side) is dangerous!

Turn Freedom Valley Drive into Town Road.2 – people. Give us something for our taxes besides a place to vote. Come & support the people & bus. that live on Freedom Valley Dr. Thousands of dollars paid in taxes, the largest employer in the township, Room taxes paid and still no support from our township, this is very sad!. 17 years of being in the Pub & Grub our township thinks all these people that live on our road don’t exist. What is paid in Property taxes on Freedom valley Dr? It’s a shame, but no support on this road. It’s been said you’re far away. We have to go thru the township of Washburn to get to you out there! Well GUESS WHAT. We have to go to the township of Washburn to go pay our property Taxes!!

Let me ask you this: Can the Township of Bayview afford to operate the township without our money in property taxes?? It has been done before where this situation was the same and they started their own township. Really a bid deal (for Freedom Valley Dr) when nothing gets talked about this problem.

Snow plow Freedom Valley Dr, we pay taxes to Town of Bayview. There are 8 permanent homes on my road that pay town taxes the same as others in Town of Bayview and get little for our efforts.

5) Are you interested in serving on the Town Roads Committee? 46 no 31 not now     yes (please provide contact info: Bob Olson 373-2641; Terry Ledin 373-0347; Mark Smith; Susan Haas 373-5535; Joe Johantik; Mark Jerabek; Mark Hart 373-0217; Brandon Madison 209-8220.

## **Parks**

The Town is considering adding additional amenities at Bayview Park, building upon the recent improvements of the pavilion, bathrooms, fire pits, and bear-proof garbage cans.

1) Do you visit Bayview Park, Friendly Valley Beach or Houghton Falls Nature Preserve (circle which ones)?

\_11\_ never \_41\_ rarely \_20\_ occasionally \_\_22\_ frequently

2) Do you use the new pavilion at Bayview Park? \_15\_ yes \_74\_ no (some say not yet)

3) Several residents have requested development of camping at Bayview Park which historically had several small campsites. The site most often suggested is west from the pavilion where the old sites are still visible. Several of these areas however have been colonized by native orchids and there is concern that these areas be considered for protection in any development.

Would you support development of camping facilities at Bayview Park (car access camping with no power hook-ups)? \_41\_ yes \_44\_ no \_9\_ no opinion

Big Rock not used. 2- people. Additional maintenance. Need time and money on roads.

Only if orchids are protected.

Very limited – low impact – conserve natural habitat.

Provided some organization takes care of fees etc.

The flowers that were planted there! The only thing native there is the pine needles.2

The pavilion & restrooms are a good idea but further development will destroy the nature of our beach.

Solar trash compactors! How about a 3<sup>rd</sup> access point between rivers w/cooperative on DOT/State Historical Society & DNR w/a board walk to beach /Madeline Island & drainage delta natural area interpretation/bath room & changing house/parking.

Years ago when it had campsites there were no flowers. Flowers were recently planted there. Not if it is only going to be destroyed as it was last time.

Keeping a garbage can at Bayview Beach and keeping it emptied.

Vandalism in the early campground days will not be different now. The Township could not take care of Big Rock campground – that is why the County has now.

The orchids are not native. Not there years ago, where did they come from.

We are unable to manage our roads and there is no extra money to spend on them. How can you even consider spending money on the parks, the cost to do the things you want may not be a lot but someone still has to maintain and road crew should be a road crew not a park crew!

What would maintenance of campsites cost? What does the Sheriff think of campsites- would it be up to sheriff to patrol campsites? What does Sheriff think of having boat racks at Bayview Park? Are there other such racks in use elsewhere so we could hear if they have been safe? Why are the former campsites no longer used – where they abandoned from disuse or closed, and why? Campsites are nice idea but what are the potential problems?

This park is for Town of Bayview – keep it that way. Keep Bayview Park for the people of the town there are no reasons for a small boat rack this beach will be for kayak use and a take over for them they were asked to leave Bayfield and Town of Russell. The people of Bayview have paid for the park out of tax money – leave it that way.

But not where orchids are.

Boat landing at or near Bayview Park – charge fee.

Once you start camping you get trash & land destruction.

I don't think the town should be in the campsite business.

I support the re-creation of a campground@ Bayview at the old site locations. Some orchids are able to withstand light disturbance and will survive. There are however some rare orchids in the area that do poorly with disturbance and may be impacted. I would be happy to offer consultation on this if you like. I am a botanist who works for a large federal land management agency in the area. Please feel free to contact me about the orchids@ Bayview and I'd be happy to help. Matt Bushman 715-373-5009

When did we get into recreation business?

Suggest you (town board) schedule a visit for Bayview residents to see where you want to develop a camping area.

4) Another proposal under consideration is the creation of a "water access" campsite on the dunes south of the Bayview Park beach access road. This would be a primitive site without car access targeted at boat campers with space for one or two groups.

Would you support development of a primitive "water access" campsite?

30 yes 50 no 9 no opinion

Burn pits on the beach have led to an increase of garbage on the beach. Beach grass near those pits have been harmed. No camping should be allowed in that fragile spot. Worry about wild orchids v/w camping is well founded. So is worry about the fragile beach environment. No camping should be allowed at Bayview. There are many other unused campsites in this County.

We find plenty of party left overs on the beach. We pick up and bring it home to keep the beach clean. We don't need more problems. There are plenty of business people who offer rental camping, showers, access to lake. These business struggle to stay a-float. They pay taxes & support our local economy. We do not need to compete!. Liability is a big issue. Vagrancy has been a big issue in Ashland. We do not need the troubles. The times we do go down we are constantly picking up garbage, condoms, diaper,s beer bottles, glass, fast food bags etc. We not think this is a good idea at all.

Who would control/maintain site? Inevitably there will be some parties and trash.

Request "deposit" refundable to cover damages (such as burying garbage etc- people will be what they are.

Camp in Washburn at Memorial Park or Big Rock Park (Sioux River).

Suggest you (town board) schedule a visit for Bayview residents to see where you want campsite. There is a fragile bog all along Bayview Beach tha has to be taken into consideration; plus DNR regs may prohibit this campsite due to proximity of bog and lake.

Litter, garbage and noise.

I think adding camping is a bad idea unless you have ways to monitor and control the sites and limit stay. I think it would encourage parties. I think a better way to improve the park would be to add bathrooms as Friendly Valley and to add more picnic tables by the pavilion.

5) The Town is considering providing small boat storage racks to keep canoes, kayaks, or other small boats at Bayview Park. These would be rented annually with priority to Town residents. Fees collected would be used to pay for Park maintenance and improvements. A location south (to the right facing the Lake) of the beach access road was identified as having minimal impact to the view of the Lake from the road and minimal impact to beach users. Depending upon interest a system with 6-12 spaces is being considered. One possible layout (approximately 7' high x 7' wide x 12' deep for 6-8 boats) is below:

### Boat Rack Design

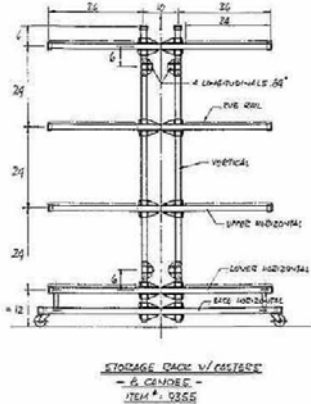

Do you support the idea of a small boat rack?

\_25\_ yes \_45\_ no \_19\_ no opinion

Would you be interested in renting a rack?

\_5\_ yes (how many? \_\_\_\_\_) \_81\_ no

What kind of boat(s) would you be storing?

\_4\_ canoe \_3\_ kayak \_\_ SUP/windsurfer \_\_ Sunfish

Would you be willing to pay \$50 - \$75/yr. for a rack?

\_8\_ yes \_38\_ no

And who is going to enforce this and check everyday that someone hasn't paid? We are not in the rec. business! This is small business enterprises. Mike and Jim already don't have time to do what they were specifically hired to do Maintenance. This needs to be put up for vote before you do anything.

The Town cannot afford Insurance and liability for such a feat. It would be an eyesore and are inviting trouble – such as children playing on them. Stealing of Boats. Also inviting problems with people using these boats along with swimmers at same time. We have a nice beach why mess with it. We cannot fix the roads properly. Are you (town board) going to hire more road crew to work at the park. Leave the Park and beach area alone.

These are tourist attractions. How about thinking about the tax payers first. I could care less about people coming from MPLS or Chicago to camp or boat here.

What about the people that live on this road? You are putting temptation up for people to climb around on and for getting hurt. The town will be responsible.

What happens when some kids go out there and steal's or damages these boats?

We don't need this! Focus on roads. The road dust stirs and contains asbestos (car brakes ) Benzine (car fluids). Go straight to the liver. Zinc oxides, mercury, lead, & chromium from autos and machinery – All known toxins and environmental hazards. Add Human poisons, if anyone has political leverage, get the roads paved like the resort /cabin district near Iron River/Barnes; all Bayfield Co. Territory. What is the count's responsibility out here in the Township of Bayview.

Who wants to look at a boat rack when you go to the lake.